

JET

JWL-1640VS WOOD LATHE

Original:

GB
Operating Instructions

Translations:

D
Gebrauchsanleitung

F
Mode d'emploi



JPW (Tool) AG

Tämplerlistrasse 5

CH-8117 Fällanden

Switzerland

Phone +41 44 806 47 48

Fax +41 44 806 47 58



www.jettools.com

M-719500M

2016 -09

**CE-Conformity Declaration
CE-Konformitätserklärung
Déclaration de conformité CE**

Product / Produkt / Produit:

Wood lathe
Drehselmaschine
Tour à bois

JWL-1640VS
719500M

Brand / Marke / Marque:

JET

Manufacturer / Hersteller / Fabricant:

JPW (Tool) AG, Tämperlistrasse 5, CH-8117 Fällanden, Switzerland

We hereby declare that this product complies with the regulations
Wir erklären hiermit, dass dieses Produkt der folgenden Richtlinie entspricht
Par la présente, nous déclarons que ce produit correspond aux directives suivantes

2006/42/EC

Machinery Directive / Maschinenrichtlinie / Directive Machines

2014/30/EU

electromagnetic compatibility / elektromagnetische Verträglichkeit / compatibilité électromagnétique

designed in consideration of the standards
und entsprechend folgender zusätzlicher Normen entwickelt wurde
et été développé dans le respect des normes complémentaires suivantes

EN ISO 12100:2010
EN 60204-1:2006+A1:2009
EN 61000-6-4:2007+A1:2011
EN 61800-3:2004+A1:2012
EN 55011:2009+A1:2010

Responsible for the Documentation / Dokumentations-Verantwortung / Responsabilité de Documentation:

Hansjörg Meier

Head Product-Mgmt / Leiter Produkt-Mgmt./ Resp. de Gestions Produits
JPW (Tool) AG



2016-09-10 Alain Schmid, General Manager

JPW (Tool) AG, Tämperlistrasse 5, CH-8117 Fällanden,
Schweiz / Suisse / Switzerland

GB - ENGLISH

Operating Instructions

Dear Customer,

Many thanks for the confidence you have shown in us with the purchase of your new JET-machine. This manual has been prepared for the owner and operators of a JET **JWL-1640EVS wood lathe** to promote safety during installation, operation and maintenance procedures. Please read and understand the information contained in these operating instructions and the accompanying documents. To obtain maximum life and efficiency from your machine, and to use the machine safely, read this manual thoroughly and follow instructions carefully.

...Table of Contents

1. Declaration of conformity

2. Warranty

3. Safety

Authorized use
General safety notes
Remaining hazards

4. Machine specifications

Machine description
Technical data
Noise emission
Contents of delivery

5. Transport and start up

Transport and installation
Assembly
Mains connection
Dust collection
Starting operation

6. Machine operation

Correct operating position
Tool selection
Speed selection
Turning between centres
Bowl turning
Sanding and Finishing

7. Setup and adjustments

Changing spindle speeds
Headstock spindle lock
Headstock rotation
Headstock spindle index
Installing work holding
Adjusting tool rest
Adjusting tailstock

8. Maintenance and inspection

Adjusting bed clamping
Pulley drive lubrication
Changing belt and bearings

9. Trouble shooting

10. Environmental protection

11. Available accessories

1. Declaration of conformity

On our own responsibility we hereby declare that this product complies with the regulations* listed on page 2. Designed in consideration with the standards**.

2. Warranty

The Seller guarantees that the supplied product is free from material defects and manufacturing faults. This warranty does not cover any defects which are caused, either directly or indirectly, by incorrect use, carelessness, accidental damage, repair, inadequate maintenance or cleaning and normal wear and tear.

Guarantee and/or warranty claims must be made within twelve months from the date of purchase (date of invoice). Any further claims shall be excluded.

This warranty includes all guarantee obligations of the Seller and replaces all previous declarations and agreements concerning warranties.

The warranty period is valid for eight hours of daily use. If this is exceeded, the warranty period shall be reduced in proportion to the excess use, but to no less than three months.

Returning rejected goods requires the prior express consent of the Seller and is at the Buyer's risk and expense.

Further warranty details can be found in the General Terms and Conditions (GTC). The GTC can be viewed at www.jettools.com or can be sent by post upon request.

The Seller reserves the right to make changes to the product and accessories at any time.

3. Safety

3.1 Authorized use

This wood lathe is designed for turning wood only. Machining of other materials is not permitted and may be carried out in specific cases only after consulting with the manufacturer.

The workpiece must allow to safely be loaded and supported.

The proper use also includes compliance with the operating and maintenance instructions given in this manual.

The machine must be operated only by persons familiar with its operation and maintenance and who are familiar with its hazards.

The required minimum age must be observed.

The machine must only be used in a technically perfect condition.

When working on the machine, all safety mechanisms and covers must be mounted.

In addition to the safety requirements contained in these operating instructions and your country's applicable regulations, you should observe the generally recognized technical rules concerning the operation of woodworking machines.

Any other use exceeds authorization.

In the event of unauthorized use of the machine, the manufacturer renounces all liability and the responsibility is transferred exclusively to the operator

3.2 General safety notes

Woodworking machines can be dangerous if not used properly. Therefore the appropriate general technical rules as well as the following notes must be observed.



Read and understand the entire instruction manual before attempting assembly or operation.



Keep this operating instruction close by the machine, protected from dirt and humidity, and pass it over to the new owner if you part with the tool.

No changes to the machine may be made.

Daily inspect the function and existence of the safety appliances before you start the machine.

Do not attempt operation in this case, protect the machine by unplugging the mains cable.

Before operating the machine, remove tie, rings, watches, other jewellery, and roll up sleeves above the elbows. Remove all loose clothing and confine long hair.

Wear safety shoes; never wear leisure shoes or sandals.

Always wear the approved working outfit:

- safety goggles
- ear protection
- dust protection



Do not wear gloves while operating this machine.



Install the machine so that there is sufficient space for safe operation and workpiece handling.

Keep work area well lighted.

The machine is designed to operate in closed rooms and must be placed stable on firm and levelled table surface.

Make sure that the power cord does not impede work and cause people to trip.

Keep the floor around the machine clean and free of scrap material, oil and grease.

Stay alert, give your work undivided attention.

Use common sense. Do not operate the machine when you are tired.

Do not operate the machine under the influence of drugs, alcohol or any medication. Be aware that medication can change your behaviour.



Keep an ergonomic body position.

Maintain a balanced stance at all times.

Never reach into the machine while it is operating or running down.



Never leave a running machine unattended. Before you leave the workplace switch off the machine.

Keep children and visitors a safe distance from the work area.

Do not operate the electric tool near inflammable liquids or gases.

Observe the fire fighting and fire alert options, for example the fire extinguisher operation and place.

Do not use the machine in a damp environment and do not expose it to rain.

Wood dust is explosive and can also represent a risk to health.

Dust from some tropical woods in particular, and from hardwoods like beach and oak, is classified as a carcinogenic substance.

Always use a suitable dust collection device

Before machining, remove any nails and other foreign bodies from the workpiece.

Make sure to guide and hold the chisel with both hands safe and tight during machining.

Work only with well sharpened tools.

Machine only stock which is chucked securely on the machine, always check before switching the machine on.

Provide workpieces with centre holes before clamping between centres.

Work large and unbalanced workpieces at low spindle speed only.

When sanding, remove the tool rest from the machine.

Workpieces with cracks may not be used.

Remove the chuck key or dowel pins before turning the machine on.

Always close the belt cover.

Specifications regarding the maximum or minimum size of the workpiece must be observed.

Test each set-up by revolving the work by hand to insure it clears the tool rest and bed. Check setup at the lowest speed before you increase to the operating speed.

Do not remove chips and workpiece parts until the machine is at a standstill.

Never stop work pieces with the hand during run out.

Do not attempt to engage the spindle lock pin until the spindle has stopped.

Never take measurements on a rotating workpiece.

Do not stand on the machine.

Connection and repair work on the electrical installation may be carried out by a qualified electrician only.



Have a damaged or worn power cord replaced immediately.

Make all machine adjustments or maintenance with the machine unplugged from the power source.



3.3 Remaining hazards

When using the machine according to regulations some remaining hazards may still exist.

The rotating workpiece can cause injury.

Workpieces that are inhomogeneous or weak can explode when being processed due to centrifugal force.

Only process selected woods without defects.

Unbalanced workpieces can be hazardous.

Injuries can occur when feeding tooling, if tool supports are not correctly adjusted or if turning tools are blunt.

Risk of kickback. The tooling is caught by the rotating workpiece and thrown back to the operator.

Thrown workpieces and workpiece parts can lead to injury.

Dust and noise can be health hazards. Be sure to wear personal protection gear such as safety goggles and dust mask. Use a suitable dust collection system.

The use of incorrect mains supply or a damaged power cord can lead to injuries caused by electricity.

4. Machine specifications

4.1 Machine description

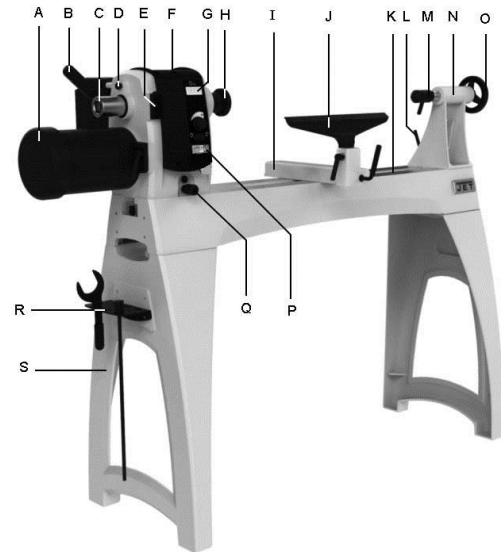

Fig 1

- A Motor
- B Headstock lock handle
- C Headstock Handwheel
- D Index pin
- E Spindle lock
- F Headstock
- G Digital readout
- H Faceplate
- I Toolrest base
- J 350mm toolrest
- K Bed
- L Tailstock lock handle
- M Live center
- N Tailstock
- O Tailstock Handwheel
- P Front-mounted controls
- Q Headstock Swivel index
- R Tool caddy with tools
- S Casting stands

4.2 Technical data

Swing over bed	405mm
Centre distance	990 & 940mm
Number of mechanical speeds	2
Spindle speed range 1	40-1200 rpm
Spindle speed range 2	100-3200 rpm
Spindle nose	M33x3,5 DIN 800
Headstock spindle taper	MT 2
Spindle index lock	36 x 10°
Tailstock spindle taper	MT 2
Tailstock hole diameter	9mm
Tailstock ram travel	108mm
Centre above floor	1130mm

Overall (LxWxH)	1854 x 1334 x 508 mm
Net weight	170 kg
Mains	1~230V, PE, 50Hz
Output power	1,1 kW (1,5 HP) S1
Reference current	8 A
Extension cord (H07RN-F):	3x1,5mm ²
Installation fuse protection	16A
Isolation class	I

4.3 Noise emission

Acoustic pressure level (EN ISO 11202):

Idling	LpA 72,5 dB(A)
In operation	LpA 78,4 dB(A)

The specified values are emission levels and are not necessarily to be seen as safe operating levels. As workplace conditions vary, this information is intended to allow the user to make a better estimation of the hazards and risks involved only.

4.4 Content of delivery

Lathe bed with headstock, tool support and tailstock – A

350mm Tool rest – B

Legs – C

Spur center – D

Live center – E

Live cone center – F

Live cone center pin – G

Knockout rod – H

75mm Faceplate – J (installed on lathe)

Tool rest extension – K

Faceplate wrench – L

Levelers – M

Tool shelf – N

Hardware:

8 Socket hd. cap screws, 5/16x1-1/4 – HP1*

8 Lock washers, 5/16 – HP2*

8 Flat washers, 5/16 – HP3*

2 Socket hd. cap screws, 3/8x1-1/4 – HP4

2 Lock washers, 3/8 – HP5

* included in JWL1440-HP1, hardware package

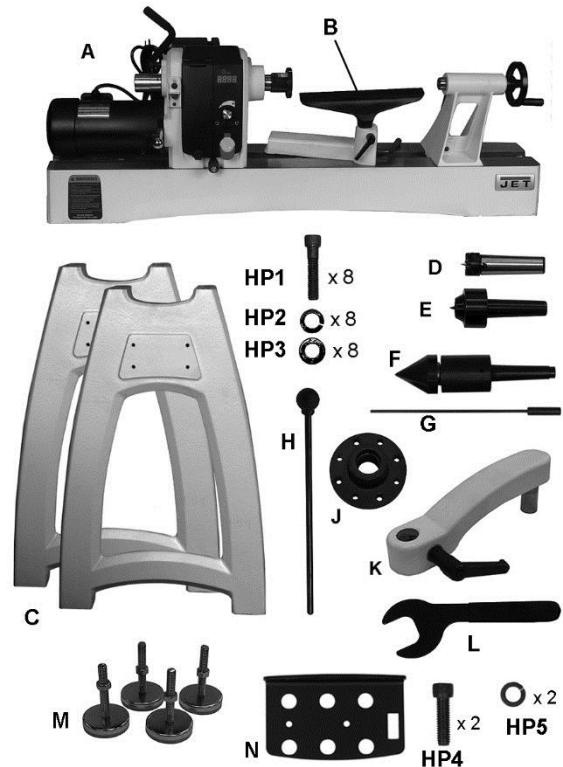

Fig 2

5. Transport and start up

5.1 Transport and installation

The machine is designed to operate in closed rooms and must be placed stable on firm and levelled ground.

The machine can be bolted down if required.

For packing reasons the machine is not completely assembled

5.2 Assembly

If you notice transport damage while unpacking, notify your supplier immediately. Do not operate the machine!

Dispose of the packing in an environmentally friendly manner.

Clean all rust protected surfaces with a mild solvent.

Attach the leg stand:

At this point the headstock, tailstock and tool rest should be removed.

Unscrew the stud (N, Fig 4) from each end of bed.

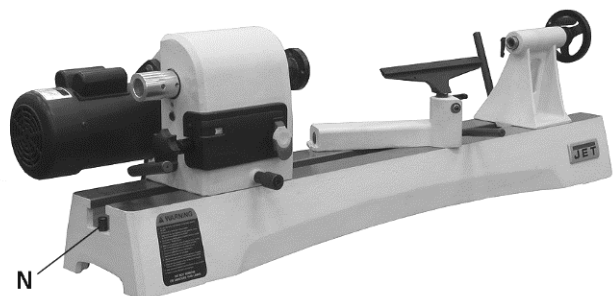

Fig 4

Remove headstock, tailstock and tool rest support from bed.

The machine bed is heavy! With the help of a second person. Carefully turn bed upside down. Place a mat or cardboard beneath it to prevent scratching the bed ways.

Install legs with eight screws, lock washers and flat washers. Tighten screws firmly with 6mm hex key. (see Fig 5).

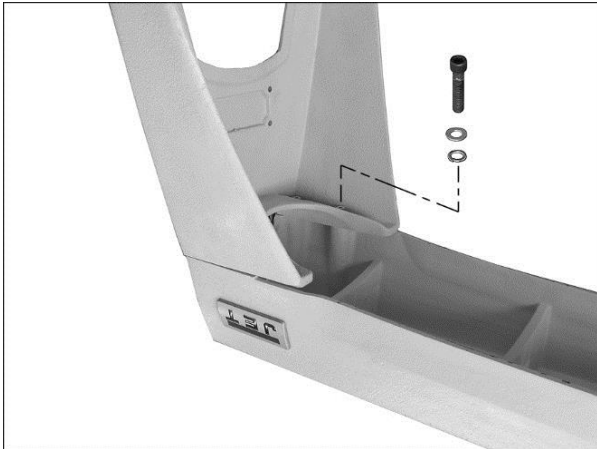

Fig 5

Install the four levellers. These can be adjusted later. (see Fig 6)

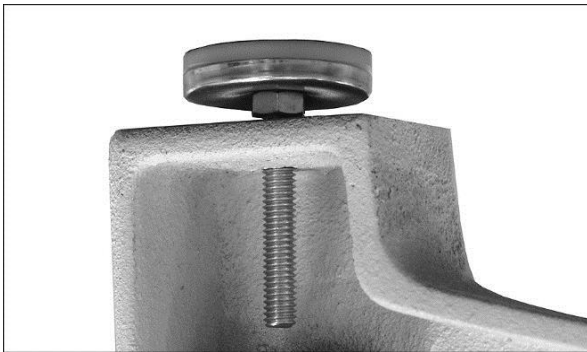

Fig 6

With the help of a second person, raise bed and leg assembly right-side up.

Rotate the levellers as needed to establish level for the lathe. Tighten the hex nut on each leveller against the leg casting.

Now headstock, tool rest and tailstock can be installed again (Fig 7).



Fig 7

Install both studs (N, Fig 4).

Stand shelf:

You can make an extra shelf that rests between the legs if you wish (see Fig 8).

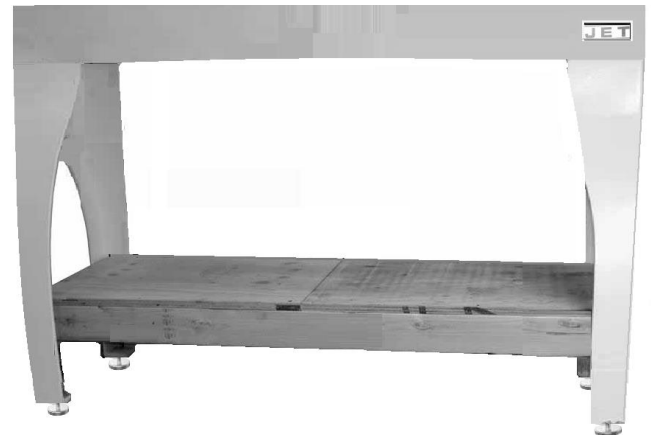

Fig 8

Installing bed extension: (JET Option # 719401)

The bed extension can be mounted to the upper or lower holes of the lathe.

Mounting the extension to the lower holes allows use of the tool support during outboard turning (Fig 9).



Fig 9

Mounting in upper holes increases the spindle length capacity of the lathe.

Have an assistant hold bed extension flush to end of lathe bed, and insert four screws with washers (P, Fig 10).

Snug screws just enough to hold bed extension to lathe bed.

Unscrew stop bolt (N) from lathe bed and insert it into hole at end of bed extension.

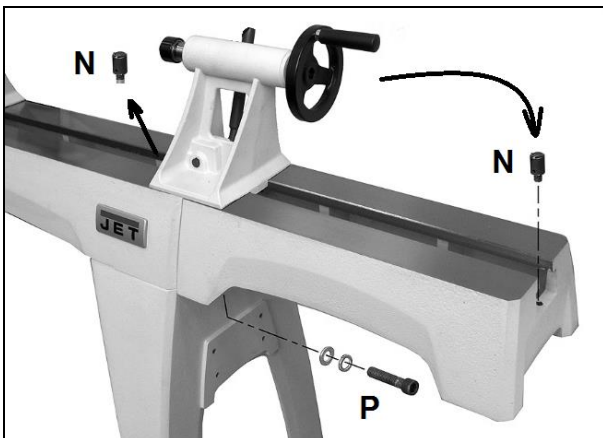

Fig 10

Top surfaces and inside ways must be flush to allow smooth movement of tailstock.

Slide tailstock over joint where beds meet, so that clamping nut is centred over joint. Lock tailstock clamping handle; this will align the beds.

Securely tighten screws (P) in bed extension.

Guard (optional accessory)

The guard (part no. 719002) is optional and purchased separately. See our website for information.

Loosen set screw on outer collar (shown in Figure 10-1) with 4mm hex key. Slide outer collar off the guard support rod.

Insert guard support rod into mounting bracket at rear of headstock. You will have to lift up on spring pin, as shown, to slide guard support rod into mounting bracket. Release spring pin and it will snap into position as you slide support rod farther in.

Install outer collar and tighten set screw.

The guard can be pivoted to one of two positions: Operating mode (shown on front cover) or tilted back for stock loading (Figure 10-2).

Pull up on spring pin, and begin tilting guard, then release spring pin. When guard reaches either of the two positions, spring pin will engage.

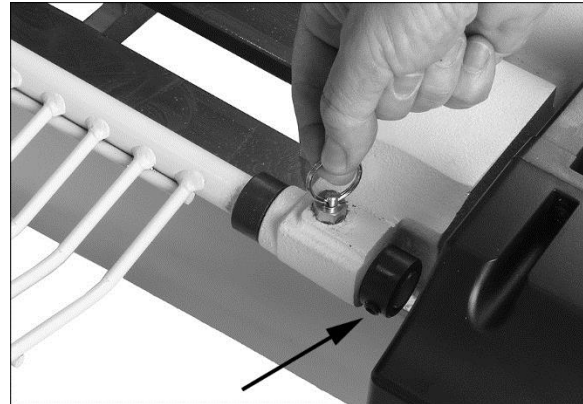

Figure 10-1

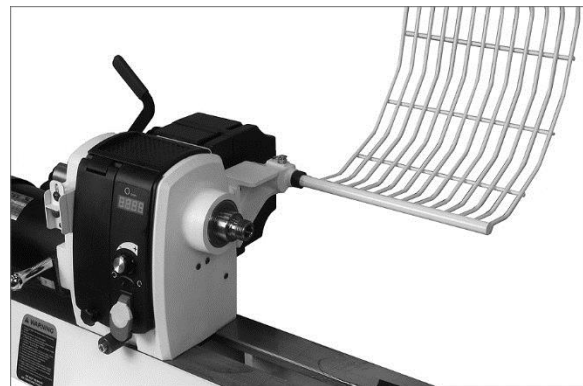

Figure 10-2

5.3 Mains connection

Mains connection and any extension cords used must comply with applicable regulations.

The mains voltage must comply with the information on the machine licence plate.

The mains connection must have a 10 A surge-proof fuse.

Only use power cords marked H07RN-F

Connections and repairs to the electrical equipment may only be carried out by qualified electricians.

5.4 Dust collection

Use a suitable dust collection and filtration system to avoid a high dust concentrations in the air.

5.5 Starting operation

You can start the machine with the green ON-button. The red OFF-button on the main switch (B, Fig 1) stops the machine.

6. Machine operation

6.1 Correct operating position

Always support the tool on the tool rest and guide with the palm of your hand keeping your fingers closed. (see Fig 11 and 12)

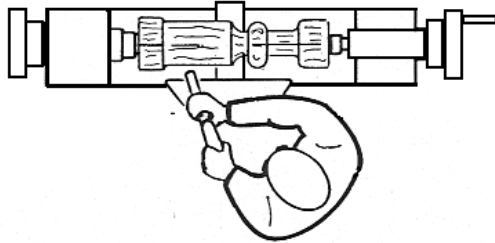

Fig 11

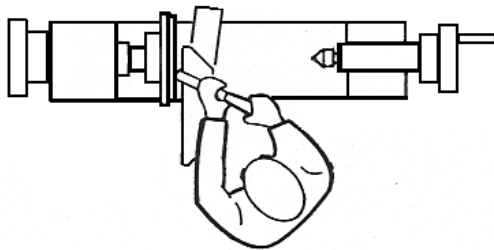

Fig 12

6.2 Tool selection:

Successful wood turning does not result from high speeds, but rather, from the correct use of turning tools.

A perfect and sharp wood turner tool is a precondition for professional wood-turning.

Major tools:

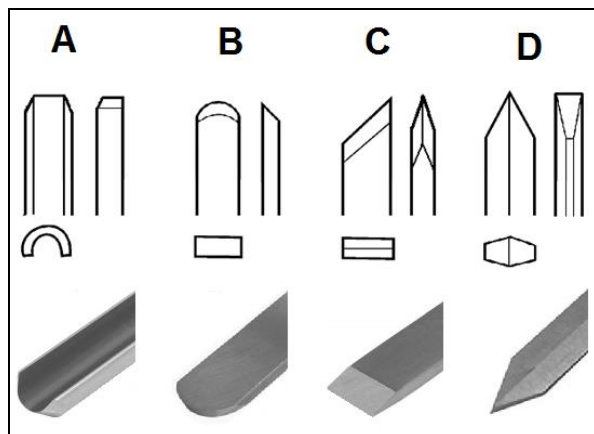

Fig 13

Gouge (A, Fig 13), used for rapidly cut raw wood into round stock, for turning bowls and plates, for turning beds, coves and other detail (Fig 14).

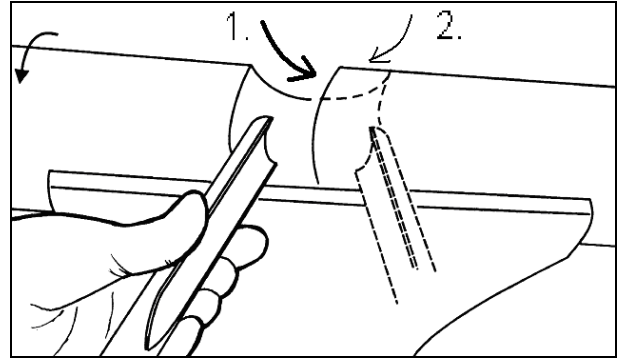

Fig 14

Scraper (B, Fig 13), used for diameter scraping and to reduce ridges.

Skew Chisel (C, Fig 13), used to make vees, beads, etc. (Fig 15). The bevel of skew is parallel to the cut.

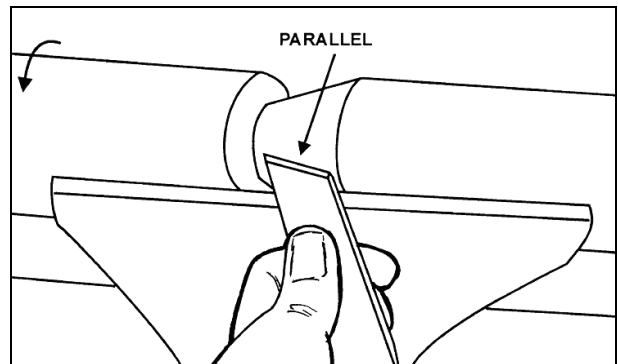

Fig 15

Parting tool (D, Fig 13), used to cut directly into the material, or to make a cut off. Also used for scraping and to set diameters.

6.3 Speed selection:

Use low speeds for roughing and for large diameter work. If vibrations occur, stop the machine and correct the cause. See speed recommendations.

Speed recommendations

Workpiece Diameter mm	Roughing RPM	General Cutting RPM	Finishing RPM
< 50	1250	2500	2500
50-100	700	1600	2500
100-150	480	1100	1600
150-200	400	900	1250
200-250	350	600	1100
250-300	350	480	900
300-350	350	350	600

6.4 Turning between centres:

With a ruler locate and mark the centre on each end. Put a dimple in each end of the shock. Extremely hard woods may require kerfs cut into the spur drive end of stock (see Fig 16).

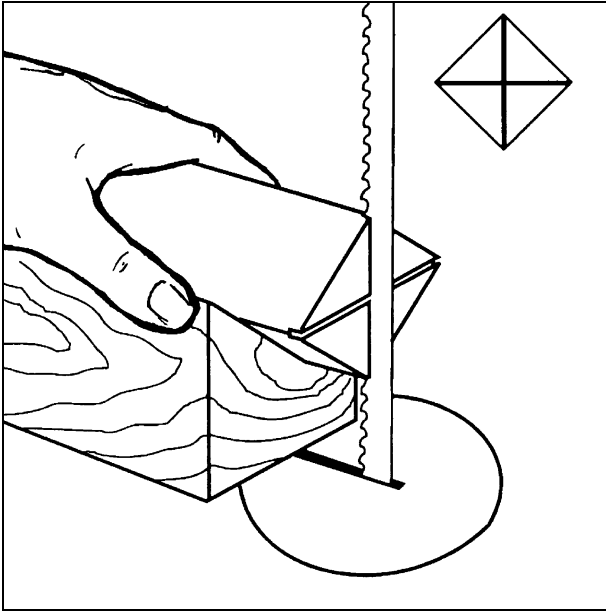

Fig 16

The spur drive centre locks into the spindle taper and can be removed with the knockout rod (Fig 17)

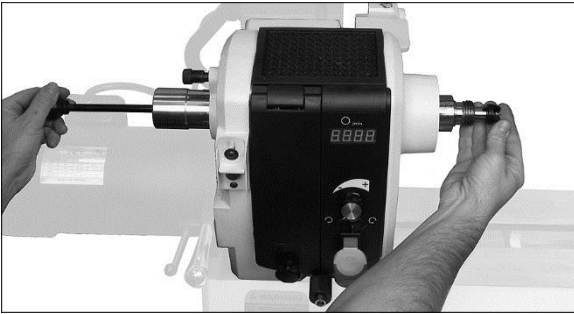

Fig 17

The live centre locks into the tail stock taper and can be removed by rotating the handwheel counter clockwise (Fig 18)

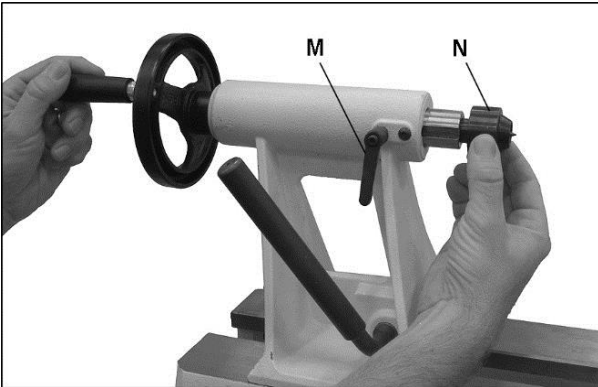

Fig 18

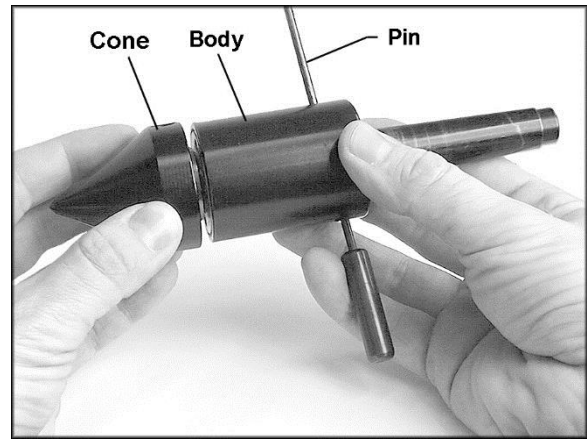

Fig 18-1

Mount the centred workpiece between the spur drive centre and the tailstock mounted live centre (Fig 19)



Fig 19

Turn the tailstock hand wheel until the live centre well penetrates the workpiece. Reverse the hand wheel by one quarter turn and lock the tailstock spindle (M, Fig 18)

Turn the workpiece by hand to see if it rests securely between centres and can be rotated freely.

The live center, shown in Figure 18-1, can be used without the cone. To remove cone from live center, first insert pin through hole in live center body as shown. If pin will not insert at first, rotate cone until pin can be inserted. The cone can now be removed by holding the body stationary while unscrewing cone.

Position the tool rest as close to the workpiece as possible. Tighten locking handles.

For turning between centres the tool rest is set approximately 3mm higher than centre line (Fig 20, 21 and 22).

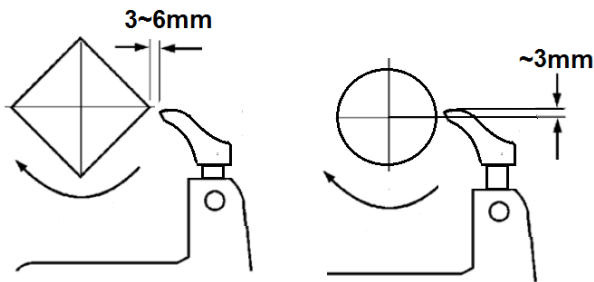

Fig 20



Fig 21



Fig 22

6.5 Bowl turning

Turn outside of bowl between centres.

Turn a short tenon the size of the hole in the faceplate (T, Fig 23). This will allow centring the workpiece.

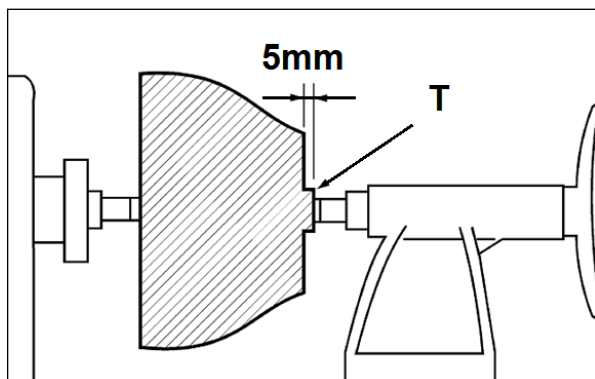

Fig 23

Mount the workpiece (A, Fig 24) directly to the face plate using 4 wood screws (C) from the back. Be careful to use screws short enough not to interfere with the cutting process but long enough to hold the workpiece securely to the face plate.

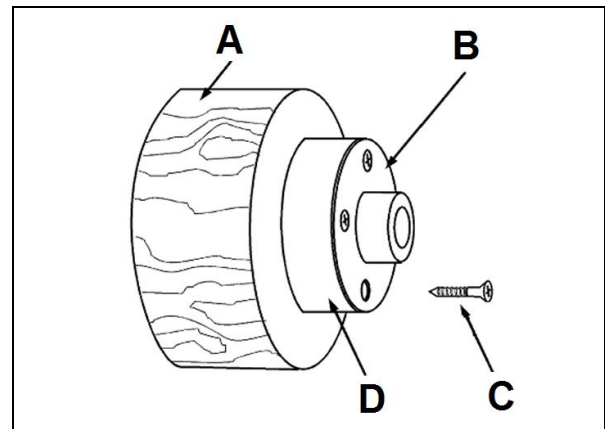

Fig 24

If screw mounting is not allowed at all, the work may be glued to a backing block (D) and the backing block screwed to the face plate. A piece of paper in the glue joint will prevent damaging the wood when separated later.

Mount the face plate with the workpiece already attached onto the spindle nose thread and hand tighten.

If reversing spindle rotation, make sure face plate, chuck or other work holding is secured with the set screws, to avoid threading loose.

Move tailstock away, remove centre from tailstock to prevent injury.

Turn the workpiece by hand to see if it rests securely and can be rotated freely.

Position the tool rest as close to the workpiece as possible. Tighten locking handles.

For face plate turning the tool rest is set slightly lower than centre line.

Caution:

Cut with your chisel on the left side of the turning centre only.

Use left hand to control cutting edge of gouge, while right hand swings tool handle around toward your body (Fig 25).

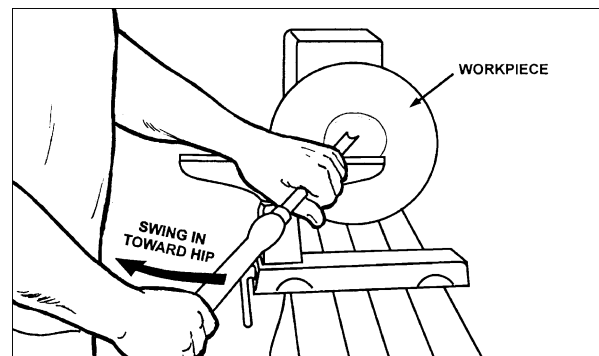

Fig 25

Try to make one, very light continuous movement from the rim to the bottom of the bowl to ensure a clean, sweeping curve through the workpiece.

Move tool support to the exterior to re-define bottom of bowl.

6.6 Sanding and Finishing:

Remove the tool rest and begin with a fine grit sandpaper (120 grit) and progress through each grit, using only light pressure.

Use power sanding techniques to avoid concentric sanding marks.

Finish sanding with 220 grit.

Apply first coat of finish. Allow to dry before sanding again with 320 or 400 grit sandpaper.

Turn lathe back on and make a separation cut through the base. Stop at about dia. 80mm and use a fine tooth saw to separate the bowl from the waste.

Apply additional finish coats and allow to dry before buffing.

7. Setup and adjustments

General note:

Setup and adjustment work may only be carried out after the machine is protected against accidental starting by pulling the mains plug.

7.1 Changing spindle speeds

Never change speeds without the motor running. Damage to the variable speed pulleys may result.

Disconnect lathe from power source.

To change speed range, open access door on headstock.

Loosen pivot lock handle (A, Figure 26) and lift up tension handle (B) to raise motor. Tighten pivot lock handle (A) to hold motor in raised position.

There should be sufficient slack in the belt to reposition it to the other steps on the sheaves. The label on access door shows required belt position (also shown in Figure 26-1).

Loosen pivot lock handle (A) and lower motor to tension belt. Be sure that Poly-V grooves of belt seat properly in corresponding groove of sheave. Do not over-tension; a very light pressure on tension handle (B) is adequate to prevent belt slippage.

Tighten pivot lock handle (A) and close access door.

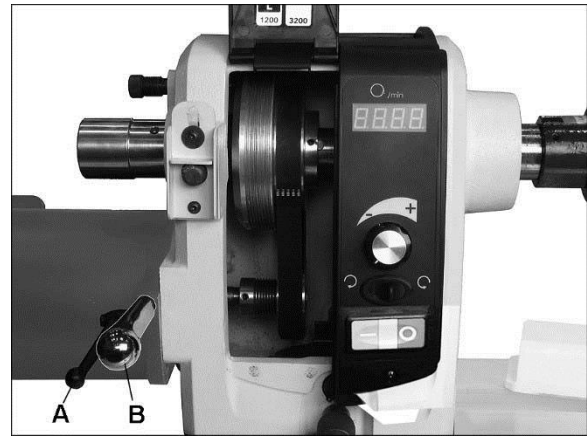

Fig 26

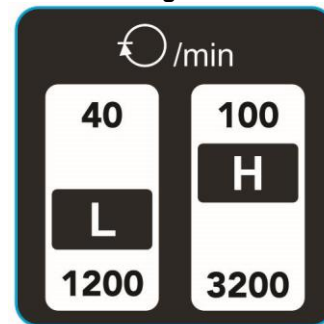

Fig 26-1

On/off switch (C): You can start the machine with the green ON-button. The red Off-button stops the machine.

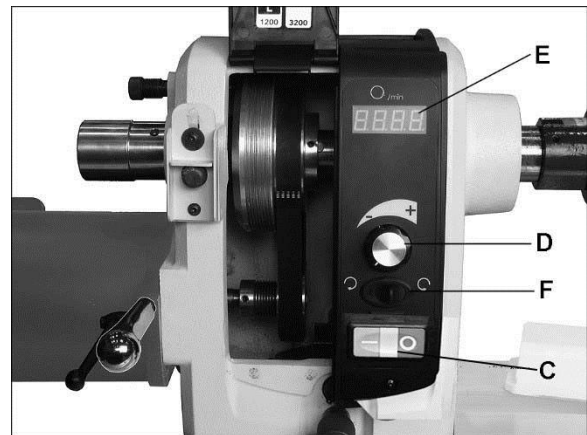

Fig 26-2

Speed control knob (D): Clockwise to increase, counterclockwise to decrease. Speed is displayed as RPM (revolutions per minute) on digital readout (E).

Forward/Reverse (F)

7.2 Headstock spindle lock

Push spindle lock pin (P, Figure 27) and rotate spindle slightly until pin engages. Slide plate downward to hold pin in locking position.

Release spindle lock by pushing plate upward.

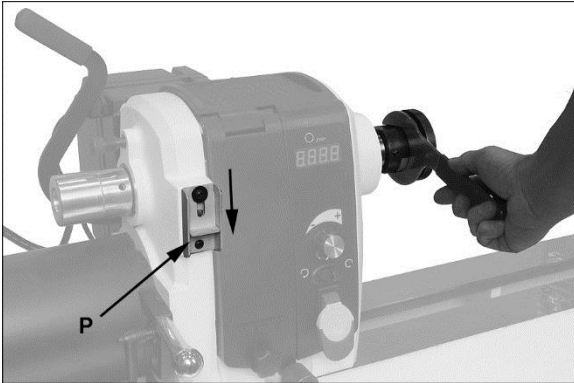

Fig 27

Caution:

Never press the spindle lock while the spindle is turning!

7.3 Headstock Rotation

IMPORTANT: Remove anti-rotation block (Figure 28) with 4mm hex key before attempting to rotate headstock.

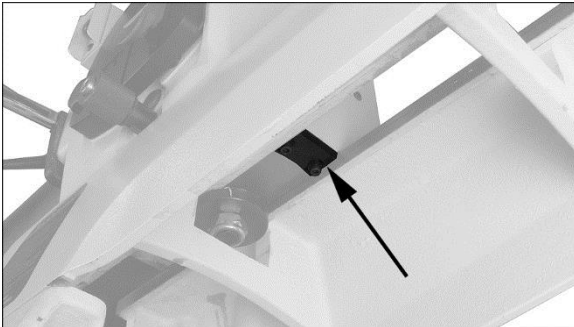

Figure 28

To rotate headstock:

Loosen lock handle (A, Figure 28-1).

Unscrew knurled knob (B) counterclockwise until it can be pulled outward.

Pull knob (B) outward and rotate headstock to desired position. The headstock has seven positive locking positions. **NOTE:** Be careful not to pinch your fingers against the bed as you rotate headstock.

Release knob (B) and it will seat itself with an audible click when the headstock reaches a positive lock position.

Lift handle (A) to lock headstock.

Rotate knob (B) clockwise until it engages the threads.

Unscrew the index plunger (B, Fig 28) counter clockwise.

Loosen the headstock lock handle (A) and pull the index plunger (B) to turn the headstock.

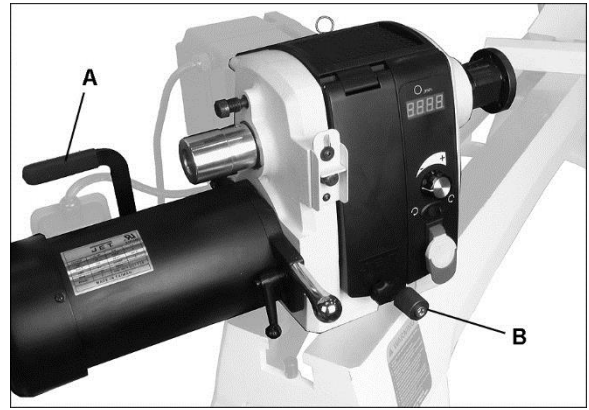

Fig 28-1

For larger workpieces the head stock will have to be turned 90°, the extension added to the tool rest.

Caution: always operate lathe with the headstock locked in position.

The headstock can be positioned anywhere along the machine bed.

7.4 Headstock spindle index

Indexing is used to create evenly spaced features in a workpiece, while keeping the lathe spindle locked; for example, when cutting flutes on a spindle blank with a hand-held router, while the spindle blank is secured between lathe centers.

The JWL-1640EVS lathe provides 36 indexing positions at 10-degree increments.

Rotate spindle using handwheel until index pin (L, Figure 29) aligns with desired hole.

Screw index pin into hole until it engages spindle.

Perform desired procedure.

Unscrew index pin until spindle is released. Rotate spindle to next desired hole, and repeat.

Disengage index pin before starting lathe.

IMPORTANT: Do not use index pin to lock spindle, which will cause unnecessary wear to the pin. Use spindle lock for this purpose.

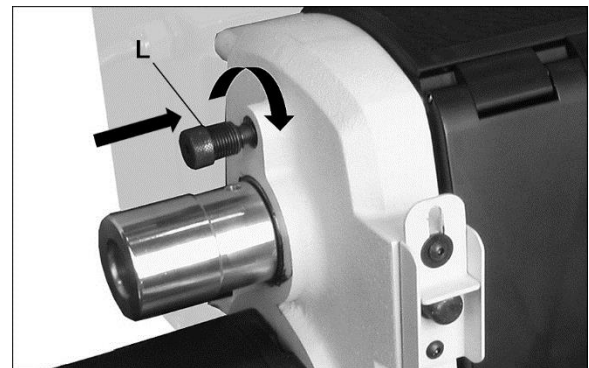

Fig 29

7.5 Installing work holding

The **faceplate** is used for turning bowls. There are a number of holes for mounting the workpiece. Thread the faceplate onto the spindle in a clockwise direction, and tighten two setscrews (E, Fig 30).

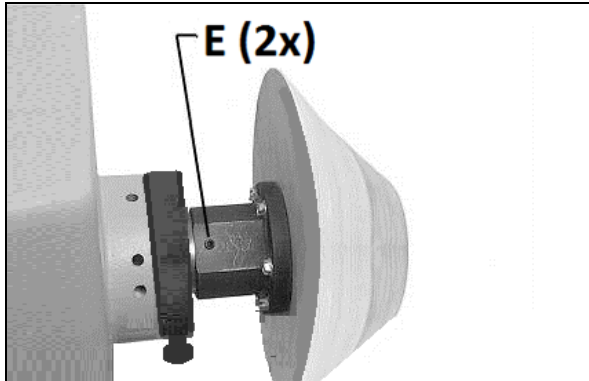

Fig 30

Remove the faceplate by loosening two set screws. Push in the spindle lock and use the provided wrench on faceplate flats.

7.6 Adjusting tool rest

A 300mm tool rest is provided with your lathe. It is designed to allow adjustment for height and position.

Loosen locking handle on tool rest base (G, Fig 31) to slide base forward or back, and to angle it to the bed. Tighten locking handle firmly before operating lathe.

Loosen handle (H) to raise or lower tool rest and angle it to the work. Tighten handle before operating lathe.

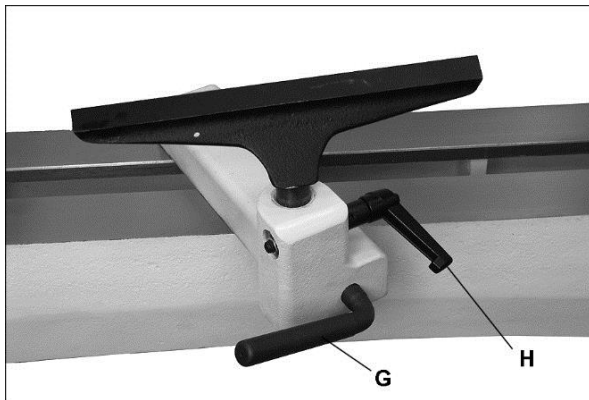

Fig 31

Tool rest extension:

The extension (J, Fig 32) mounts to the tool rest base and offers greater reach for the tool rest when turning off the bed using the headstock at an angle, as shown.

Make sure the clamp bushings (K) are pulled apart sufficiently to accept the post of the extension.

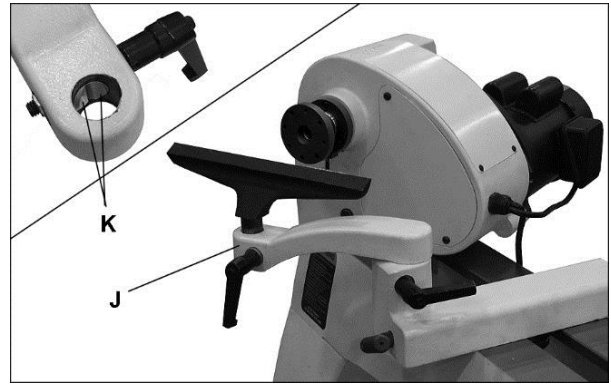

Fig 32

7.7 Adjusting tailstock

Turn the hand wheel (R, Fig 33) clockwise to move tailstock spindle forward. Lock tailstock spindle with the indexable knob (Q).

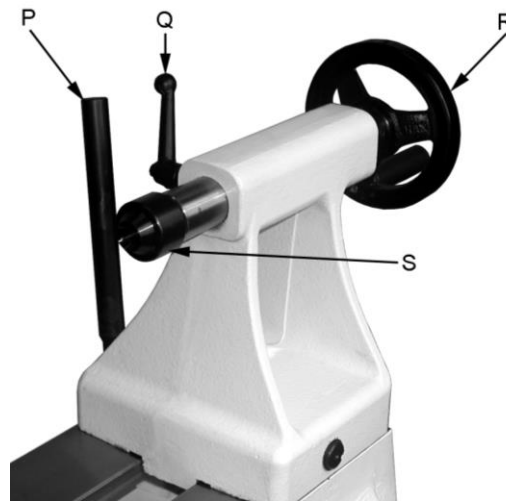

Fig 33

The handle (P) locks the tailstock in position on the bed.

The live centre (S) can be ejected by turning the hand wheel counter-clockwise.

The live centre pin can be removed to allow deep hole drilling operations.

8. Maintenance and inspection

General notes:

Maintenance, cleaning and repair work may only be carried out after the machine is protected against accidental starting by pulling the mains plug.

Clean the machine regularly.

Inspect the proper function of the dust collection daily.

Defective safety devices must be replaced immediately.

Repair and maintenance work on the electrical system may only be carried out by a qualified electrician.

8.1 Adjusting bed clamping

If adjustment is needed, remove the stud (N, Fig 4). Slide the headstock, tailstock or toolrest to the edge of the bed and slightly turn the hex nut (F, Fig 34). Test the handle to make sure it securely locks.

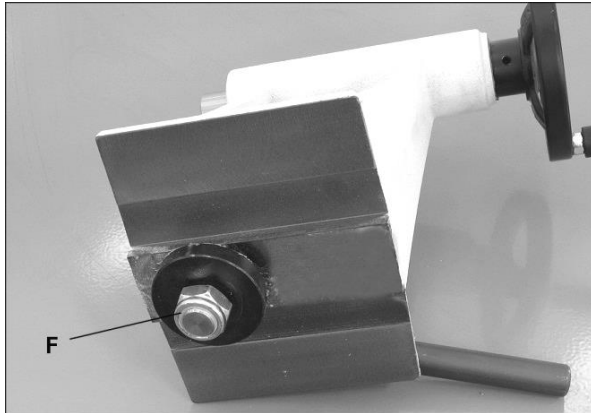

Fig 34

8.2 Pulley and belt replacement

The motor and spindle pulleys are aligned with each other by the manufacturer, but if any service is performed that affects their alignment it is very important that they be realigned. Engage spindle lock, loosen two set screws on spindle pulley (E, Figure 35) with 3mm hex key, and slide spindle pulley into proper position. Retighten set screws, and disengage spindle lock.

When pulleys and belt are properly aligned, there should be no unusual pulsing sounds or noise coming from the belt.

3mm hex key required.

To change out a belt or pulley, carefully proceed as follows. If you are uncertain about attempting a belt or pulley change-out, contact JET technical service or take the headstock to an authorized service center.

1. Disconnect lathe from power source.
2. Loosen pivot lock handle (A, Figure 35) and lift up tension handle (B) to raise motor.
3. Tighten pivot lock handle (A) to secure motor in raised position.
4. Slip belt off pulleys.
5. Loosen two set screws on handwheel (C).
6. Engage spindle lock (D) and unscrew handwheel from spindle (left-hand threads, clockwise to loosen).
7. Slide spindle a little way out of headstock, just enough to remove pulley or belt.

NOTE: If needed, tap end of spindle with a wood block or rubber mallet to move it. Do **NOT** use a steel face hammer directly against spindle.

8. If replacing a pulley, loosen both set screws (E), and slide pulley off spindle.
9. Install new pulley, loosely securing the two set screws. Make sure pulley is oriented properly and key is inserted properly in spindle groove.
10. Slide spindle back into place.
11. Reinstall handwheel (C) and tighten set screws.
12. Align new pulley then tighten both set screws securely on pulley.
13. Loosen pivot lock handle (A) and lower motor using tension handle (B). Re-tighten pivot lock handle.
14. Disengage spindle lock.

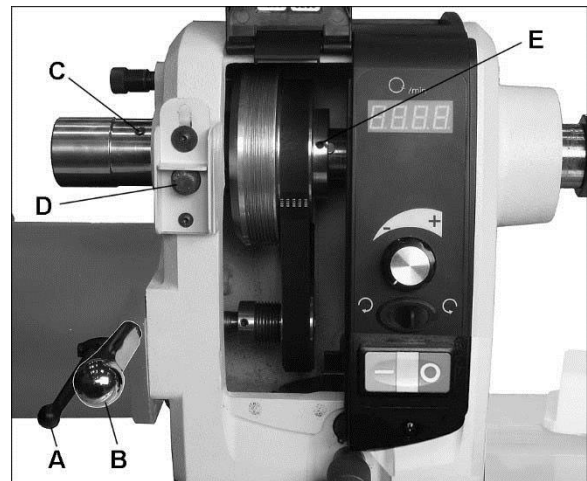

Fig 35

8.3 Changing belt and bearings

Changing belt and bearings can be a difficult task. Remove headstock and take into a repair station for servicing.

9. Trouble shooting

Motor doesn't start

*No electricity-
check mains and fuse.

*Defective switch, motor or cord-
consult an electrician.

*Overload detected on AC-drive unit-
wait and restart machine; chose low speed range belt setting (40-1200 rpm) for better torque.

Machine vibrates excessively

*Stand on uneven floor-
adjust stand for even support.

*Workpiece is not properly centred

*The speed is too high

*Workpiece is not properly centred-

*The speed is too high-

Tailstock moves

*Cam lock nut needs adjusting-
Tighten cam lock nut.

*Bed and tailstock mating surfaces greasy or oily-
Remove tailstock and clean surfaces

*Excessive pressure applied-
Slide tailstock to right side of lathe against stop (N, Fig 10).
Move headstock into position and then apply pressure.

10. Environmental protection

Protect the environment.

Your appliance contains valuable materials which can be recovered or recycled. Please leave it at a specialized institution.

11. Available accessories

Stock number 719401

Bed extension 508mm with tool post extension



Stock number 719001

Tailstock swing away



Stock number 719002

Guard

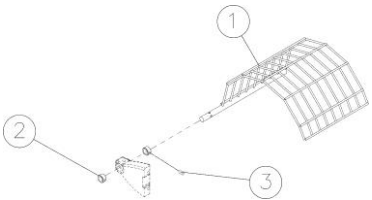

Stock number 708331

Live centre MT2

Stock number 708343K

Drill chuck 13 mm, with tapered mandrel MT-2

Stock number 709911

Face plate 75mm, M33x3,5

Stock number 709942

Four toothed spur centre MT-2

Stock number 708349

Heavy outboard turning stand

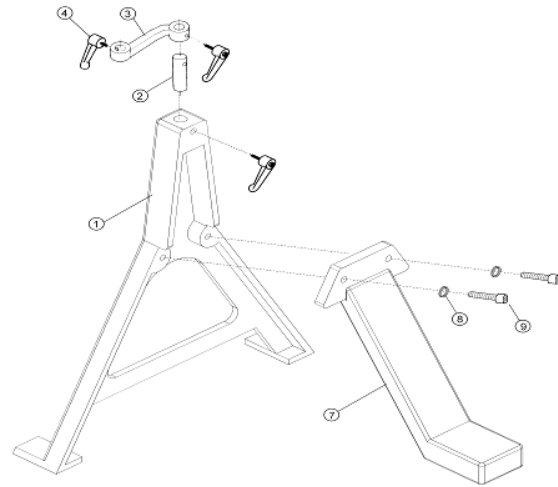

Refer to the JET-Pricelist
for various tools and work holding.